

G. Lewis.

Wood-Turning Lathe.

N<sup>o</sup> 73985

Patented Feb. 4, 1868.

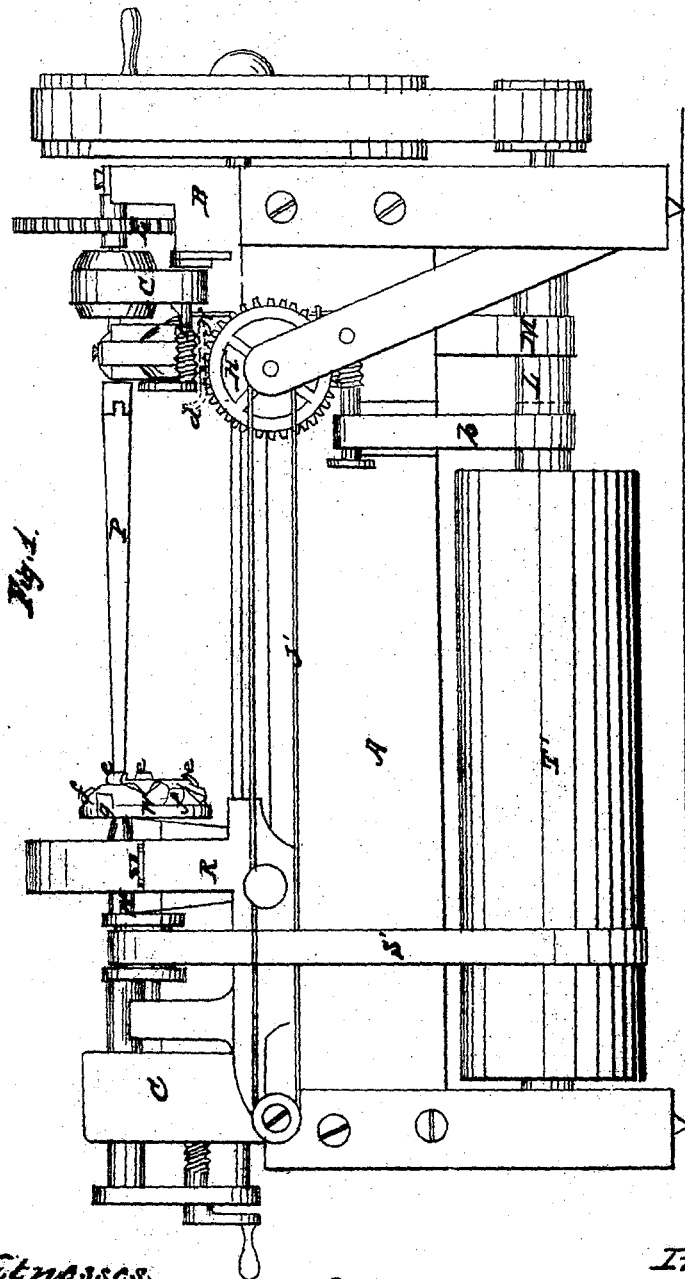

Witnesses:  
*J. H. Burdick*  
*Frank S. Alden.*

Inventor  
*George Lewis*

G. Lewis.

Wood-Turning Lathe.

N<sup>o</sup> 73985

Patented Feb. 4, 1868

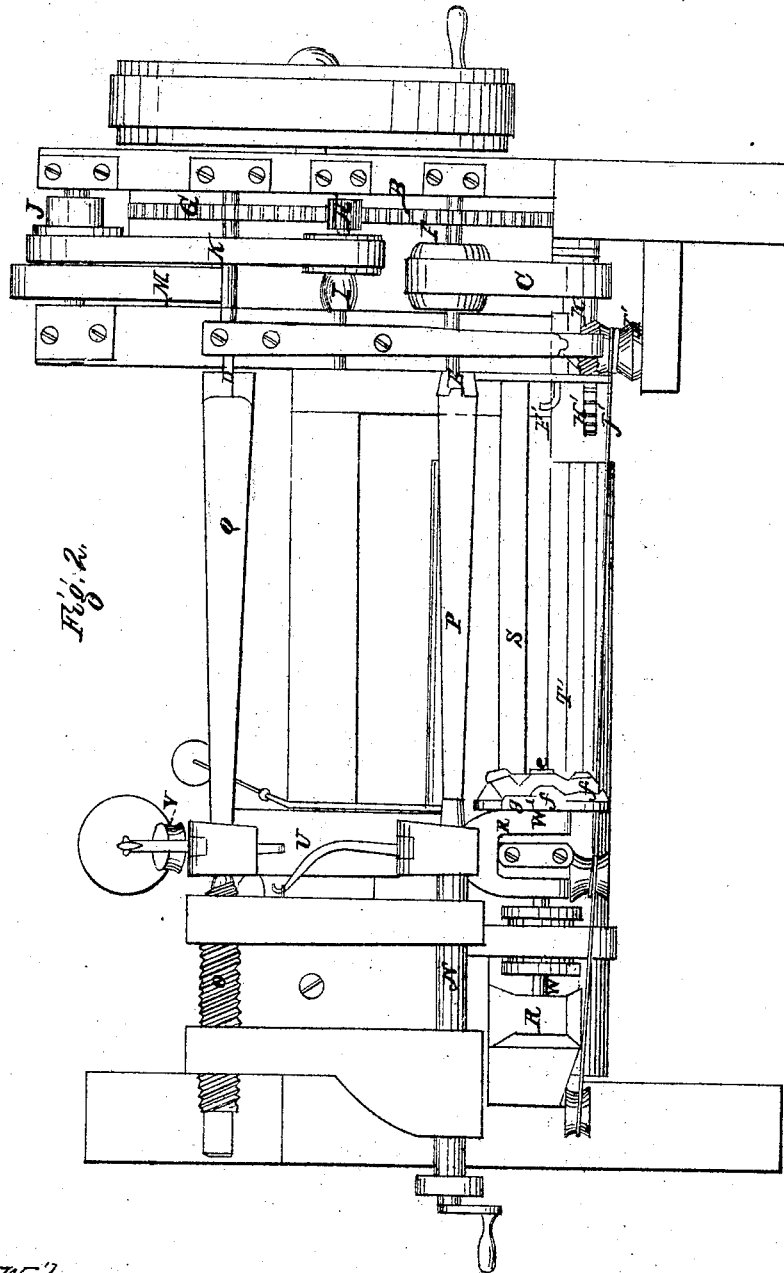

Fig. 2.

Witnesses,

J. H. Burridge  
Frank S. Alden

Inventor,

George Lewis

G. Lewis.

Wood-Turning Lathe.

N<sup>o</sup> 73985

Patented Feb. 4, 1868.

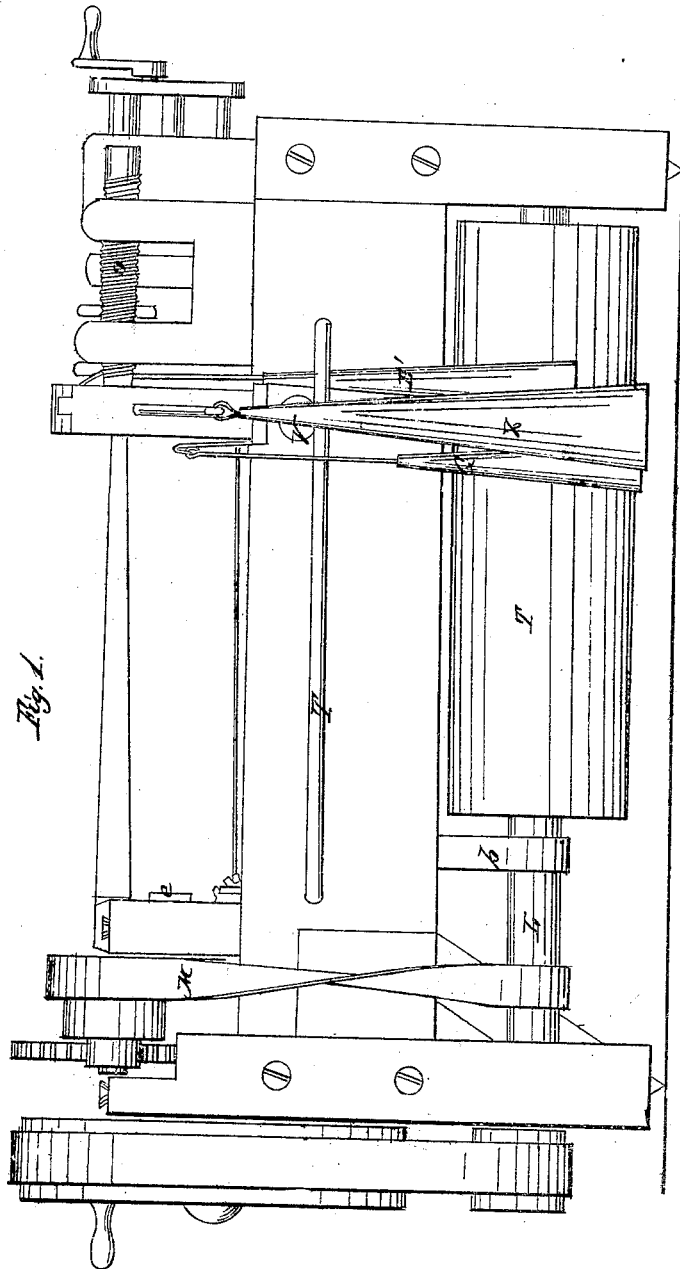

Fig. 1.

Witnesses,  
J. H. Burrige  
G. Alden

Inventor,  
George Lewis

G. Lewis.

Wood-Turning Lathe.

N<sup>o</sup> 73985

Fig. 2. Patented Feb. 4, 1868.

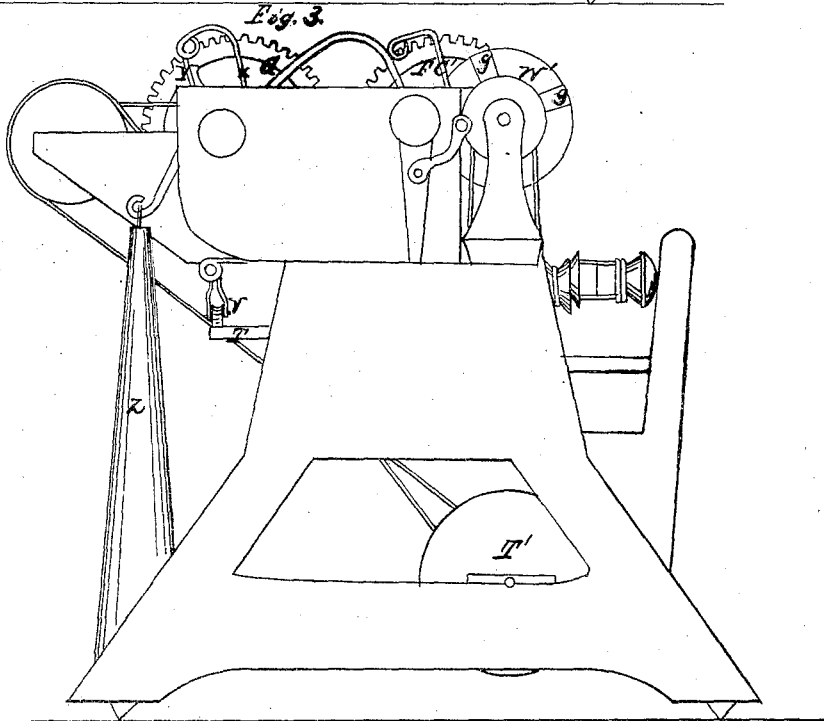
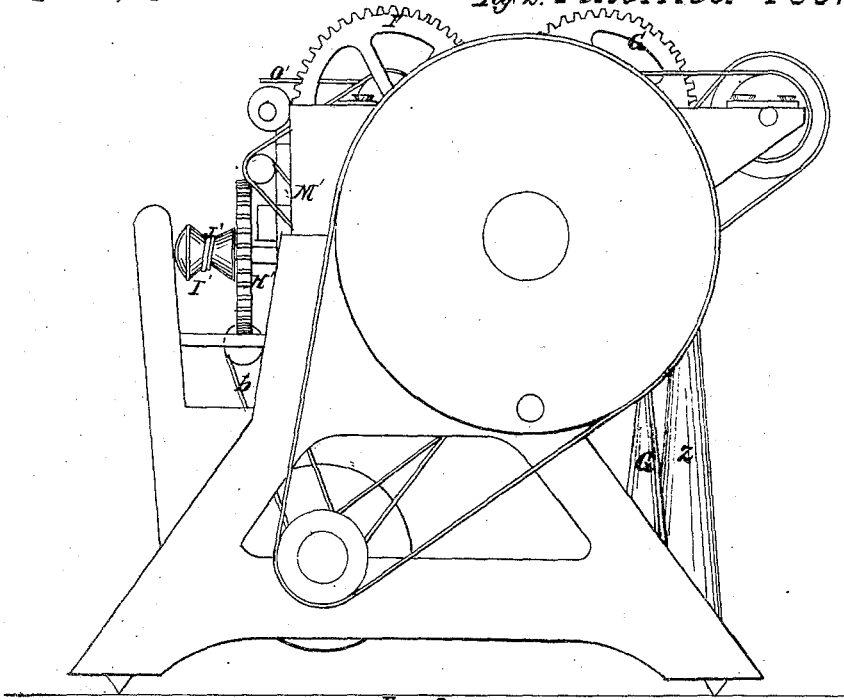

Witnesses.  
J. M. Burrieger  
Frank S. Alden

Inventor:  
George Lewis



# United States Patent Office.

GEORGE LEWIS, OF WESTFIELD, OHIO.

Letters Patent No. 73,985, dated February 4, 1868.

## IMPROVEMENT IN WOOD-TURNING LATHES.

The Schedule referred to in these Letters Patent and making part of the same.

### TO ALL WHOM IT MAY CONCERN:

Be it known that I, GEORGE LEWIS, of Westfield, in the county of Morrow, and State of Ohio, have invented certain new and useful Improvements in Machines for Turning Spokes, &c.; and I do hereby declare that the following is a full and complete description of the construction and operation of the same, reference being had to the accompanying drawings, making a part of this specification, in which—

Figure 1, Plate I, is a view of the front side of the machine.

Figure 2 is a view of the top.

Figure 1, Plate II, is a view of the rear side.

Figures 2 and 3, views of each end.

Figure 4 is a transverse section.

Like letters of reference refer to like parts in the several views.

Of this machine, A, fig. 1, Plate I, is a frame, which may be constructed of iron or wood. Across the top of this frame, at each end, are fixed supplementary frames, B C, of which B is the head, and C the foot-frame. In the head-frame are journaled the live centres or drivers D E, fig. 2, and which are driven by an arrangement of gearing, consisting of the cog-wheels F G keyed to the outer end of the centres. These wheels are engaged in a pinion, H, and by which they are driven, said pinion being operated by the pulley I, connected to the pulley J by the belt K, the pulley J, in turn, receiving motion from the drum-shaft L, fig. 1, to which it is belted by the belt M, and which drum and shaft receive motion from any power that may be employed for driving the machine. In the foot-block or frame C are secured the dead-centres N O, fig. 2. On the centres N E is placed the bolt or timber P, which, in this instance, is supposed to be a spoke. In the centres O D is placed the pattern Q, from which the spoke, axe-helve, or other work is shaped, as will hereafter be shown. R, fig. 1, is a carriage, in which is mounted, on the shaft W, the cutter-head W', and which is driven by the belt S' and drum T', fig. 1, Plate I. This carriage is made to move reciprocally along the frame on the guide-rod S, fig. 2. The cross-piece U of the carriage is supported upon the rod or way T by a friction-roller, V, fig. 3, Plate II, and by which it is also supported above the top of the frame A, as shown in fig. 4. One side of this cross-piece is hinged to the shaft W of the cutter-head, which allows of its being lifted up from the free or weighted end, and also to be moved transversely in connection with the transverse movement of the carriage, as and for a purpose hereafter shown. Projecting upwards from the cross-piece U, fig. 4, Plate II, is a standard, X, to the upper end of which is hinged a dependent arm Y, to which is hung the weight Z. It will be observed that on the inner side of the standard X is fixed a tension-spring, A', and which is kept pressed outward against the pattern Q by the adjusting-screw B'. On the opposite end of the cross-piece is projected another standard, C', fig. 4, Plate II, and which is also provided with a hinged dependent arm, D', to which is suspended the weight E'. Between this arm and standard lies the spoke D, and by which it is kept from trembling while being turned by the dependent arm, which is made to press hard against the spoke by the weight E'; also, to assist in keeping the work from trembling, a curved lever, F', is pivoted to the top of the cross-piece in the stay a, fig. 4. This lever is so adjusted that the short arm passes under the spoke and presses upward against it by the reverse action of the long arm, to which is hung a weight, G'. By this arrangement of the lever, standard, and dependent arm, the spoke is safely held from trembling, and the work leaves the machine smooth and free from cutter-marks.

The feed-work of this machine consists of the wheels H', fig. 1, Plate I, on the shaft of which is secured a pulley, I', fig. 2, around which is wound a cord or chain, J', the ends of which are attached to the carriage R. The wheel-H', referred to, is operated by the screws K' L', fig. 1, which are so arranged as to engage in the opposite diameter of the wheel, and which are driven by the belts b c. The wheel H' is so arranged that it can be thrown into and out of gear with the screws K' L', by having the inner end of its shaft journaled in an adjustable stay, M', fig. 2, Plate II. Thus, on pushing the stay up, the wheel engages in the screw K', and is held thus engaged by a spring, N', fig. 1, Plate I, which falls into a notch cut in the side of the adjusting-stay, but which, on being forced out of the notch, as will hereafter be shown, the wheel drops down and engages in the screw L', and is held thus engaged by the spring O', fig. 2, Plate II, which presses down upon the top of the stay, and thereby holds it in place.

Having thus described the construction and arrangement of the machine, the practical operation of the same is as follows, viz: A pattern of the thing to be turned is put in the lathe, on the centres D O, which, in this instance, is supposed to be a spoke, as shown in fig. 2, Plate I. In the centres N E is placed the wood or bolt from which the spoke is to be turned. The pattern and bolt, being thus properly arranged, the carriage is run down to the foot-block, as shown in fig. 2, Plate I, thus bringing the centre's head to the felloe-end of the spoke. The machine is now started, and as the bolt revolves, and the carriage is drawn towards the head of the lathe, the cutter is made to vibrate or approach and recede from the bolt, as the shape of the pattern may determine. Thus the cross-piece U, being hinged to the shaft of the cutter, and the carriage in which it is journalled so attached to the guide-rod as to admit of its turning as well as sliding upon it, is made to vibrate more or less, according to the irregular character of the pattern, which, as it turns, pushes the cutter-head from the bolt by pressing against the side of the standard X, by the greater diameter of the spoke-pattern, and as the revolving pattern presents its shorter diameter to the standard, the cutter-head is drawn toward the spoke by the weights Z and E', and thus will cut the bolt more or less, and of the same shape as the pattern. As the vibration of the cutter-head is governed by the shape of the pattern, when the carriage and cutter have traversed the length of the lathe or spoke, the end of the carriage presses upon the shaft-rod F', fig. 2, Plate I, also indicated by the dotted lines *d*, fig. 1. This rod passes behind the adjustable stay, and strikes upon the spring N', and forces it out from the notch, and thus allows the feed-wheel H' to drop and engage with the screw L', which causes a reverse movement of the wheel, and thereby runs the carriage back to the foot of the lathe from which it started. By means of the spring A' and adjusting-screw B' the standard is kept in close contact with the pattern, and thereby made to follow with greater certainty its various curvings, and cause a direct and immediate change in the transverse action of the cutters upon the bolt, so that an exact copy is made from the pattern. The cutter-head referred to is provided with three sets of cutters, *e f g*, fig. 1, Plate I, and which are so arranged that the first, *e*, of which cuts or roughs but the bolt; the second, *f*, cuts down the rear the size required; and the third, *g*, follows, to smooth and finish off the work which comes from the machine, so smooth that but little labor is required for the final finish.

I am aware that lathes have been constructed for turning irregular forms; but in all of these the cutter-head has been so arranged as to have no vibratory movement. In this particular the head is a fixture, the pattern and bolt being made to approach to and recede from the cutters or vibrate; whereas in my machine the pattern and bolt are not made to vibrate, but rotate only, the cutter-head being made, as above described, to vibrate while revolving and cutting the bolt. Also in the machines referred to, the pattern and bolt are made to traverse longitudinally the length of the work, thus bringing the work to the cutters. In my machine the order of action is reversed; in this the cutters are made to traverse the length of the work, while the pattern and bolt remain stationary in respect to any longitudinal movement.

The advantages resulting in this peculiar construction of the lathe are that it is much more simple in its constructive arrangements, requiring less machinery, and hence is less expensive, and less liable to get out of order. It is more certain and complete in its operation, and, with an equal operative power, will perform a greater amount of work.

What I claim as my improvement, and desire to secure by Letters Patent, is—

The combination of the reciprocating vibrating carriage R, cutter-head W', cross-piece U, standards X C, spring A', adjustable arms Y D', lever F, and weights Z E, all constructed, combined, and arranged in relation to the pattern Q and spoke P, and operating in the manner and for the purpose substantially as set forth.

GEORGE LEWIS.

Witnesses:

J. H. BURRIDGE,

J. HOLMES.